

# CD/N



## GENERALITA' / FEATURES

Elettropompe centrifughe monogiranti, monoblocco, ideali per pressurizzare impianti idrici domestici ed industriali, piccole e medie irrigazioni.

*Single impeller centrifugal electric pumps, enbloc. Used for domestic and industrial booster plants, small and medium irrigation.*

## MATERIALI / MATERIALS

- Corpo pompa in ghisa
  - Supporto motore in ghisa
  - Albero in acciaio inox AISI 416
  - Girante, acciaio AISI 304 o NORYL®
  - Tenuta meccanica in ceramica-grafite
- 
- *Cast-iron pump body*
  - *Cast-iron motor bracket*
  - *Stainless steel shaft AISI 416*
  - *Impeller of stainless steel AISI 304 or NORYL®*
  - *Ceramic graphite mechanical seal*

## MOTORE / MOTOR

- Motore chiuso autoventilato
  - Grado di protezione: IP44
  - Alimentazione monofase 230V- 50Hz, autoprotetto con condensatore permanentemente inserito
  - Alimentazione trifase 230/400V- 50Hz, con protezione a cura dell'utente
- 
- *Enclosed self-ventilated motor*
  - *Protection degree: IP44*
  - *Single-phase feeding 230V-50Hz, with built-in motor protector, capacitor permanently connected*
  - *Three-phase feeding 230/400V-50Hz, user changed with relevant protection*

## LIMITI DI IMPIEGO / OPERATING CONDITIONS

- Pressione massima 6 bar
  - Temperatura acqua max 50°C
- 
- *Max. pressure 6 bar*
  - *Max. water temperature 50°C*

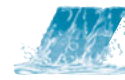

ELETTROPOMPE CENTRIFUGHE MONOGIRANTE  
 SINGLE-IMPELLER CENTRIFUGAL ELECTRIC PUMPS

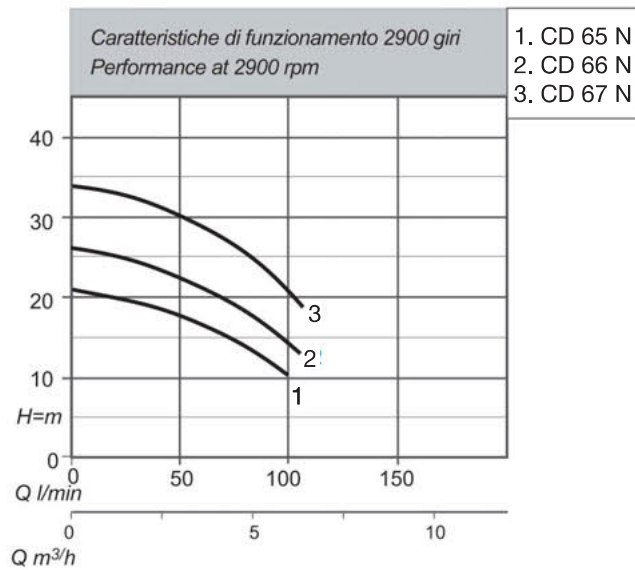

CARATTERISTICHE TECNICHE 2900 GIRI / TECHNICAL PERFORMANCE AT 2900 RPM

* Modello Model	Pot. nominale Nominal power		AMPERE	Q=Portata - Capacity								
				m <sup>3</sup> /h 06		1,2	2,7	3,6	4,5	5,4	6,3	7,2
Monofase Single-phase 230V 50Hz	Hp P2	kW P2	Monofase Single-phase 230V	Prevalenza manometrica totale in m C.A. Total head in meters w.c.								
				l/min 10		20	45	60	75	90	105	120
CD 65/N	0,5	0,37	2,8	21,5	21	17,5	16	14	12			
CD 66/N	0,8	0,59	4,5	26,5	26	23,5	22	20	17,5	14		
CD 67/N	1,0	0,74	5,7	33	32,5	30,5	29,5	27,5	25	21		

Caratteristiche di funzionamento per servizio continuo, con altezza di aspirazione fino a 6 m e  $\gamma=1 \text{ Kg/dm}^3$ . Per aspirazione oltre 4 m installare un tubo aspirante con diametro interno maggiore del diametro della bocca aspirante.  
 Performance specified refer to continuous operation, with a manometric suction lift of 6 m and  $\gamma=1 \text{ Kg/dm}^3$ . For suction over 4 m install a sucking pipe with internal diameter larger than the suction connection.

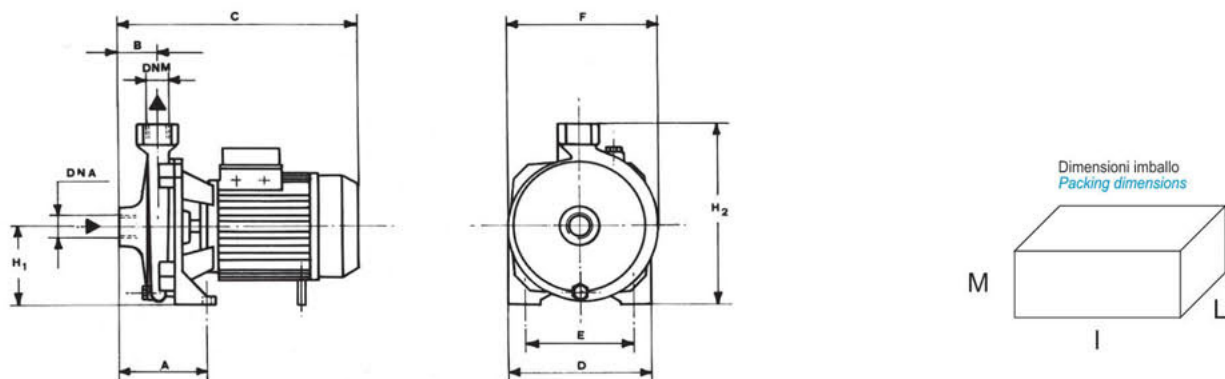

MODELLO POMPA PUMP'S MODEL	DIMENSIONI POMPA mm PUMP'S DIMENSIONS mm										DIMENSIONI IMBALLO mm PACKING DIMENSIONS mm			PESO WEIGHT kg
	A	B	C	D	E	F	H1	H2	DNA	DNM	I	L	M	
CD 65/N	95	44	265	150	110	160	82	202	1"G	1"G	290	175	225	9
CD 66/N	110	45	300	180	140	185	97	234	1"G	1"G	325	200	265	12
CD 67/N	110	45	300	180	140	185	97	234	1"G	1"G	325	200	265	14